

- **WHHR-Maxi & Maxi Plus BY**
- **Maxi & Maxi Plus BY+LCD**  
(with integral LCD screen)
- **Maxi & Maxi Plus BY-AT**  
(with acoustic attenuation and integral LCD screen)



**Residential Whole House Heat Recovery Units**

**Summer Bypass & Frost Protection**

**Low Energy EC Motor**

**Optional Humidistat**

**INSTALLATION, OPERATING AND MAINTENANCE INSTRUCTIONS**

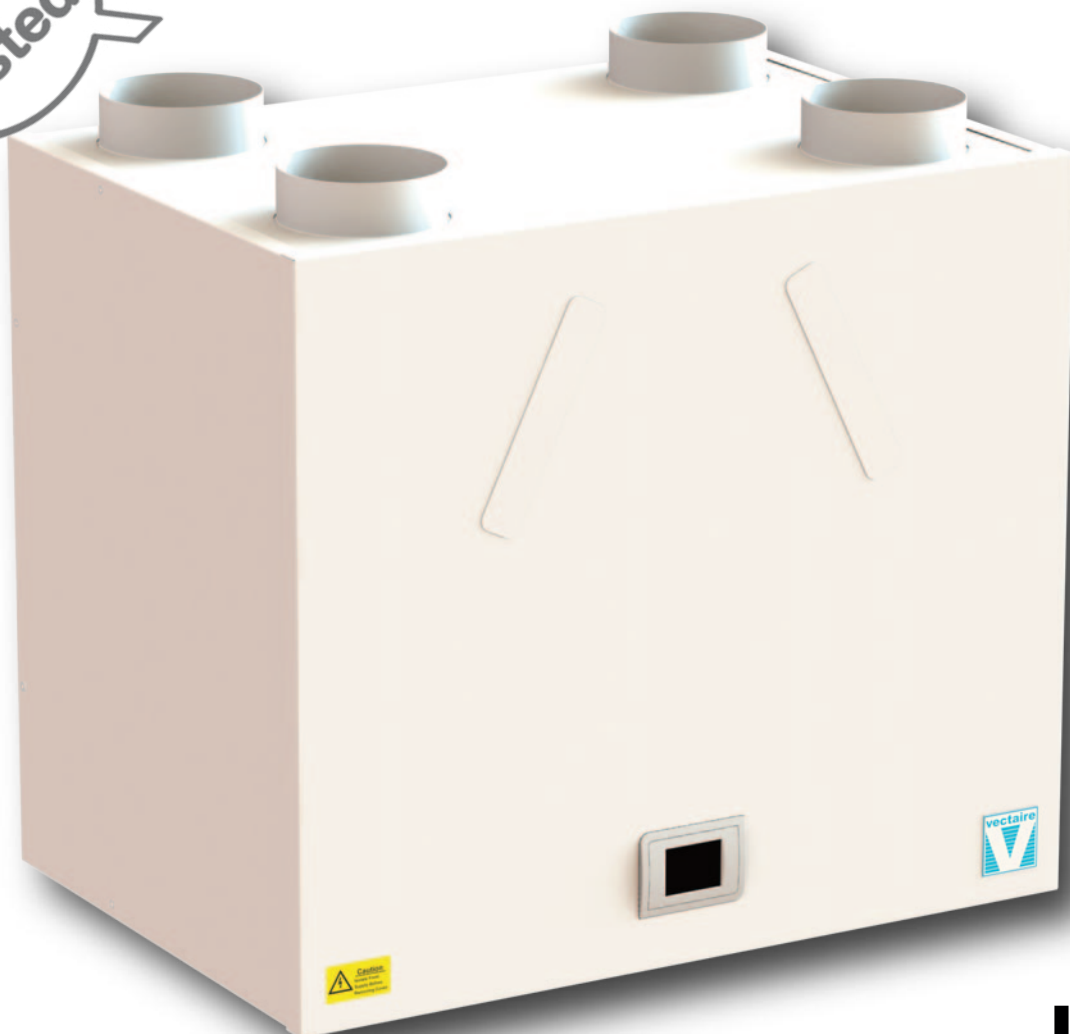

Image of model with LCD screen





# "WHHR MAXI & MAXI PLUS" - WHOLE HOUSE HEAT RECOVERY UNIT INSTALLATION AND OPERATING & MAINTENANCE INSTRUCTIONS

## Safety Notice

It is important to read this Instruction Manual carefully before installing or using the product. Following these instructions will ensure that your ventilation system is installed, commissioned and used properly and continues to operate effectively. Vectaire will not be held responsible and will not accept liability for any damage caused to persons or property through failure to follow the guidance provided in this manual. It should always be available with the product for easy reference.

**WHHR - Maxi:** 6"/150mm spigot, for dwellings up to 250m<sup>2</sup>, max capacity 177 litre/sec

**Maxi Plus:** 6"/150mm spigot, for dwellings up to 400m<sup>2</sup>, max capacity 238 litre/sec

## General Information

The Vectaire WHHR Maxi/Maxi Plus heat recovery systems provide whole house mechanical ventilation to living areas, bedrooms, kitchen and bathrooms. They extract stale, contaminated air from kitchens, utility rooms and bathrooms, and use the heat recovered from this air to warm fresh, incoming air to create a flow of fresh, filtered air throughout the dwelling. The extract and intake air streams are separated to avoid contamination.

The system will operate continuously to create a stable, comfortable, healthy environment avoiding the use of excessive energy and saving heat already generated.

The heat recovery unit must be installed vertically, and will generally be sited in a cupboard. It will be connected by hidden ductwork to vents sited in the ceilings of the rooms which are to be ventilated. Each unit is commissioned individually so that the amount of air moved is tailored to suit the performance required. There will be a facility to boost the extraction rate when desired (e.g when cooking or bathing, or when pollutant levels rise). This may be done automatically or manually.

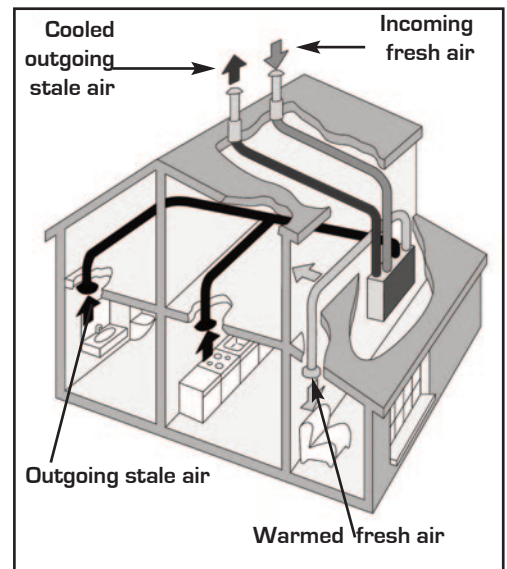

**The system is designed to run continuously and should NOT be switched off except for maintenance or filter replacement. It is important to follow the advice in this user manual and correctly install and maintain the system to ensure a healthy and comfortable indoor environment.**

## Features

- **SAP PCDB Listed** whole house heat recovery units giving continuous ventilation in the kitchen and up to seven additional wet rooms (using rigid ducting)
- low noise levels
- variable choice low (trickle) speed and boost options for optimum setting at installation
- boost speed triggered by a switched live connection from:
  - a light switch (if more than one light switch is used, **each one must be a double pole switch**)
  - DRH240 (dynamic remote humidistat)
  - PIRFF (passive infra red)
  - THM (thermostat)
  - a remote switch/pull cord
- Can be mounted with left or right hand drainage and ducting
- Economical EC motor with electronic control plus:

### Standard control features:

- > **variable adjustment** - trickle and boost speeds set at installation for both motors independently
- > **boost setting** - with integral overrun timer adjustable up to 20 minutes
- > **optional delay-on-timer** - boost speed does not operate if switched off within 2 minutes
- > **integral frost-stat** - proportionately reduces intake motor speed as temperature falls
- > **purge boost** - for rapid air change
- > **BMS connections** - for remote motor shut off
- Installation **MUST** be carried out by suitably qualified personnel and **MUST** be in accordance with current IEE regulations

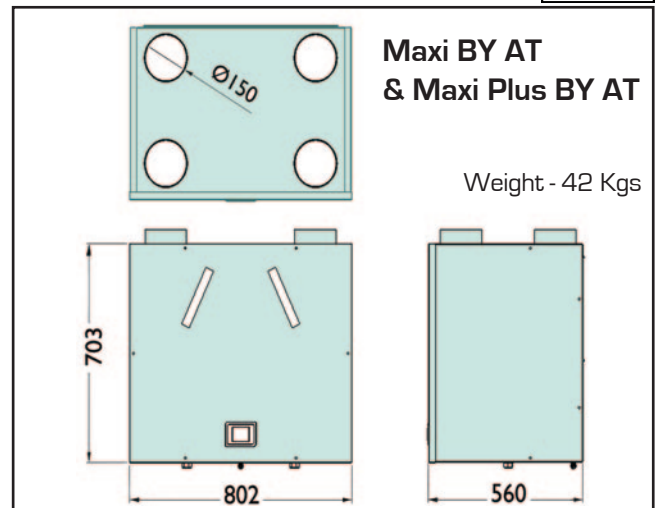
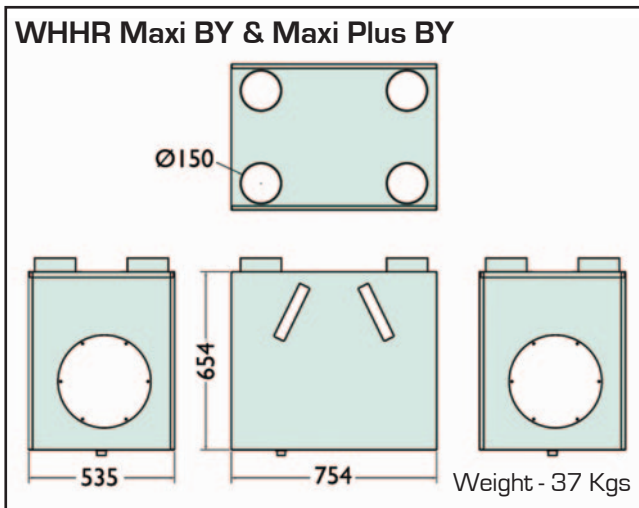

### Installation

#### IT IS IMPORTANT THESE INSTRUCTIONS ARE READ FULLY BEFORE INSTALLATION

- This product should not be used for any purpose other than that for which it was designed and as shown in this leaflet
- All packaging should be removed and the unit checked for damage in transit. If there is any damage, please contact your supplier
- The WHHR Maxi/Maxi Plus must be installed vertically, and generally be fitted into a cupboard, loft or ceiling void.
- **In order to comply with Construction (Design & Management) Regulations, sufficient access for safe maintenance (recommended on an annual basis), or removal following installation, MUST be provided for this product. We recommend that a clearance of at least 200mm is available on each side of the cabinet to allow access to the motors. See dimensions diagram.**
- Regulations and current Building Regulations. In order to comply with these, it may be necessary to fit fire dampers or other similar devices within the associated ductwork.
- **Flue gases from fuel-burning equipment must not be drawn into a living area. If any room from which air is extracted contains a fuel burning appliance, such as a central heating boiler, then its flue must be of the sealed or balanced flue type, or allowance must be made for an adequate supply of air into the room.**
- The unit must **NOT** be installed:
  - where there is excessive oil or grease
  - where there are hazardous gasses, liquids or vapours that are flammable or corrosive
  - in ambient temperatures above 40°C or lower than 0°C
  - in areas of excessive humidity or in a wet environment
- Where possible the unit should **NOT** be installed directly above a bedroom or living room.
- The condensation drain **MUST** be fitted
- Care should be taken to ensure that ducting is free from blockages
- External grilles should be located a minimum of 600mm from any flue outlet in accordance with all Regulations
- The unit must be connected to a 230-240v, 50Hz single phase electrical supply.
- A triple pole isolation switch with contact separation of at least 3mm must be used to connect the appliance to the fixed wiring when using the Switched Live.
- The product should only be connected to the mains electricity supply or electrical outlet if:
  - your electrical voltage and frequency correspond to those shown on the rating label.
  - the capacity of your electricity supply is sufficiently powerful to operate the product at its maximum power.
- If one of the spigots is not connected to ducting a safety grille **MUST** be fitted to that spigot, so that it is impossible for any moving part to be touched.

Installation of the appliance **MUST** be carried out by a qualified and suitably competent person and should be carried out in clean, dry conditions where dust and humidity are at minimal levels. The unit is not suitable for installation to the exterior of the dwelling.

#### Transportation, packaging and storage prior to installation

- Care should be taken when transporting the unit. Please be aware that the Maxi and Maxi Plus weigh 37 Kgs, and the "AT" versions weigh 42 kgs. We recommend the use of appropriate handling and lifting equipment. Dropping or knocking will damage the inner workings of the unit..
- The unit should always be stored in a clean, dry environment.
- Remove all packaging before installation.



**Pre-inspection**

- Inspect the unit and electrical supply cord for any damage (damage must be repaired by a suitably qualified and competent person.)
- Check all parts are supplied as shown.

**Parts list**

- 1 x Vectaire WHHR Maxi or Maxi-Plus unit.
- 2 x Wall mounting brackets.
- 1 x Installation, Operation & Maintenance Instructions

Any parts shortages or faults must be reported to the supplier immediately.

**Installation - mounting - Duct and Duct Connections**

(refer to design drawing)

- 4 x 150mm nominal diameter spigots are provided for the connection of ducting. These are clearly marked for correct connection of the supply and exhaust ducts.

**NB. ductwork installer should mark the "as installed" tick box on the label on the top of the unit to show whether it is left or right handed.**

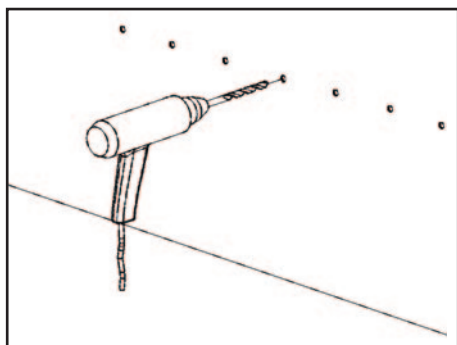
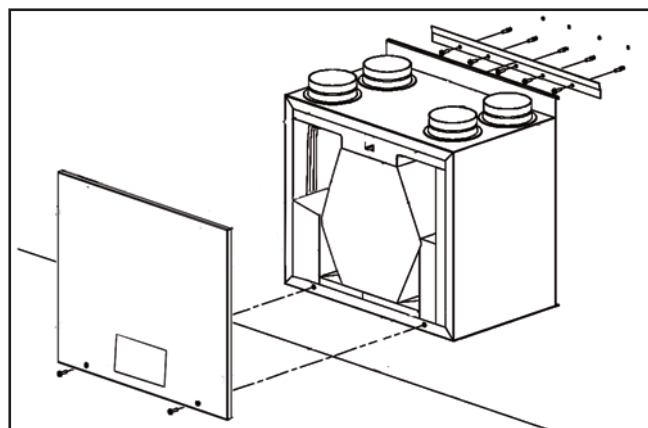
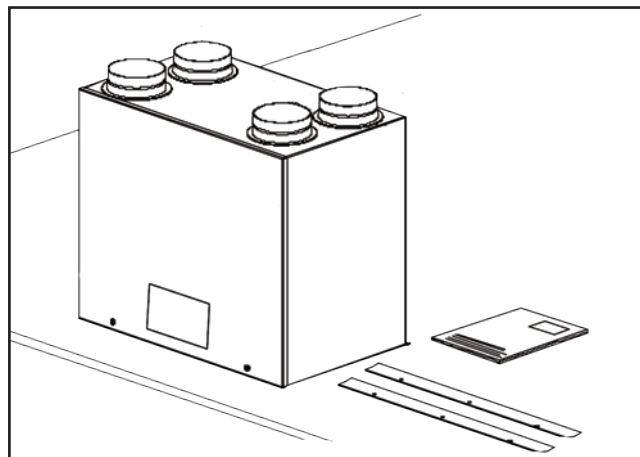

2. Drill the holes and fit wall plugs. (**Note:** if the unit is **not** being mounted on a solid wall, ensure that appropriate fixings are used.)

**N.B** When removing the main front cover, it is important that the wires connecting the circuit board to the main front cover are first disconnected to avoid causing damage to the LCD screen. (Does not apply to "AT" models)

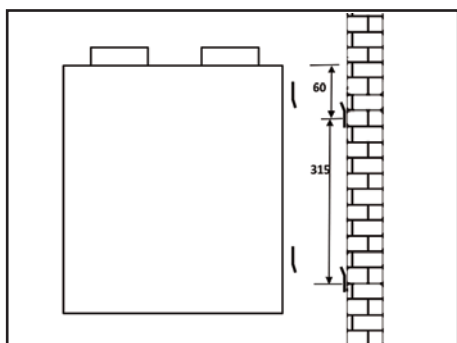

4. Mark a horizontal line on the wall 315mm below the hole centres for the upper bracket. Repeat steps 2 and 3 for the lower bracket.

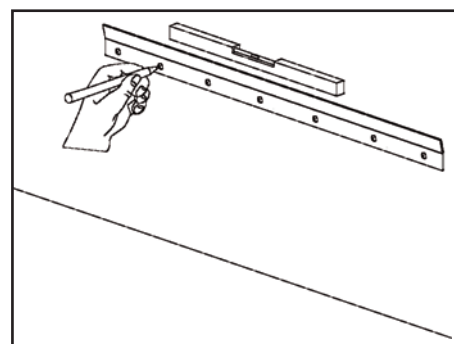

1. Mark a horizontal line on the wall using a spirit level. This line will be approximately 60mm below the location of the top face of the unit when fitted (excluding duct ports). Use the mounting bracket as a template to mark the fixing hole centres.

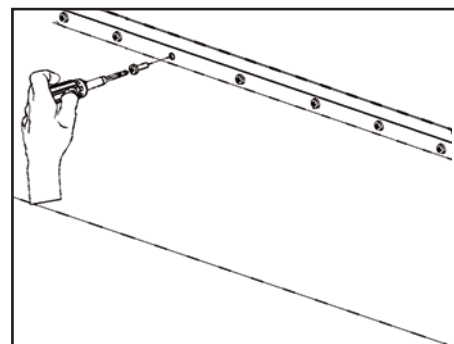

3. Fix the upper mounting bracket to the wall ensuring the interlocking side is at the top, as shown

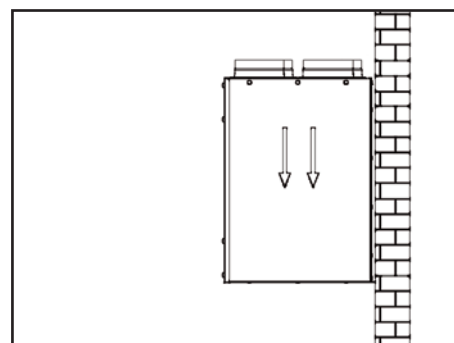

5. Mount the unit by locating the brackets on the back of the unit securely over the wall brackets.

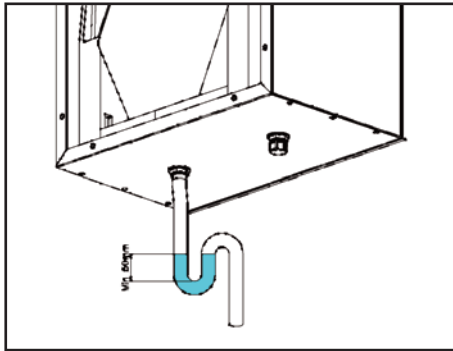

## 6. Condensation

- (The unit may sometimes produce condensation which must be drained away. A 21.5/22mm dia pipe outlet is provided on this unit).

**Note: optional left or right hand drain connectors (21.5/22mm) are fitted. A drainage pipe must be connected to the appropriate side, dependent on the positions of the supply and extract ducting. Refer to figs A and B.**

- If the ducting is installed as shown in Fig A, the drain must be connected to the left-hand outlet. If the ducting is installed as shown in Fig. B, the drain must be connected to the right-hand outlet. The unused drain outlet must be capped off.
- The drainage pipe must be installed with a continuous fall from the cabinet to the external household drainage point and a wet or dry trap must be fitted to prevent return air penetration.

- If any part of the condensate drain pipe passes through an unheated space, it must be insulated with the equivalent of at least 25mm of insulating material with a thermal conductivity of 0.04 W/mK.

- Where ducting is installed in an **unheated** space, all of the ducts should be insulated. Where ducting is installed in a **heated** space, only the cold ducts should be insulated. i.e. the supply duct from outside and the extract duct from the unit to the outside.

- The duct layout must be designed to suit the requirements of the ventilation/heat recovery system and building layout.

- Where rigid duct is used, it should be installed using the least number of fittings to minimise air flow resistance. Where possible, final connection to the grilles and unit should be made with a flexible connection.

- Where flexible ducts are used, ensure that:
  - lengths of ducting are no longer than 300mm in any one place
  - the duct is stretched so that it is smooth and straight
  - where bends are necessary, they have large radii (ie avoid sharp bends)
  - the duct is not crushed if in a restricted area

- Where ducting passes through a fire partition, suitable fire dampers **must** be installed to prevent the transmission of fire through the duct.

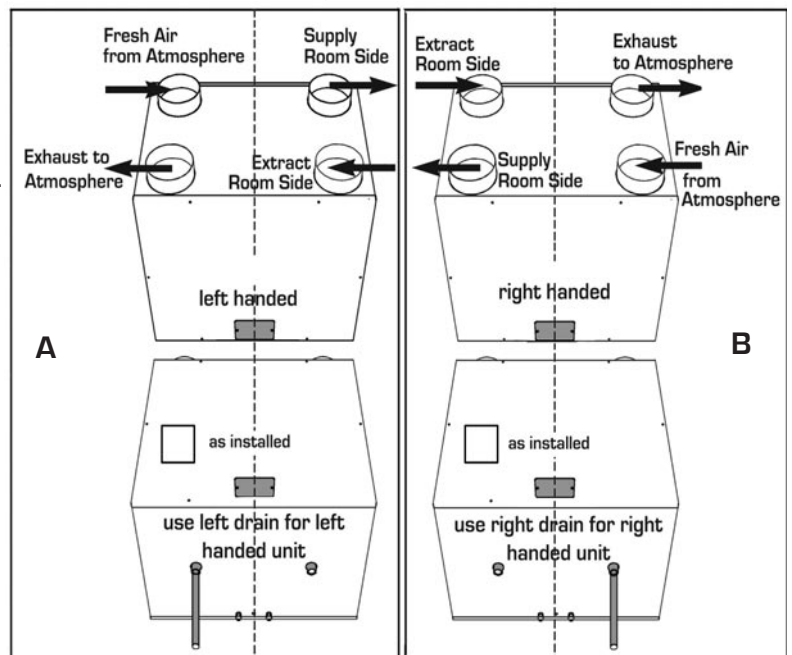

Condensate pipe MUST always be connected to ATMOSPHERE side of unit

## Electrical Connection

**WARNING: these appliances must be earthed and all wiring must conform to current IEE Regulations and all applicable standards and Building Regulations.**

- The unit is suitable for 230V, 50Hz Single phase supply.

- The unit is supplied with:

The unit is supplied with:

- A mains rated 4 core flexible cord (black, brown, grey, green/yellow)
- An optional factory-fitted 2 cord volt-free flexible cord for purge switching

Cables for any other external device will be **provided and labelled on request**

- A triple pole isolation switch with contact separation of at least 3mm must be used to connect the appliance to the fixed wiring when using the Switched Live.
- Boost controls must not be located within 1 metre of a cooker or where they may be affected by excessive heat or moisture.
- Boost and other external controls should be clearly identified and conveniently located.
- The boost facility can be activated by a switched live connection (in addition to the permanent supply live). The switched live can be operated by a variety of external devices, including:

- PIRFF (passive infra red)\*
  - DRH240 (dynamic remote humidistat)\*
  - THM (thermostat)\*
  - a light switch (if more than one light switch is used, **each one must be a double pole switch**)
  - a remote switch/pull cord
- or via LCD control

(\*PIRFF, DRH240 and THM may have integral over-run timer which controls the length of time that the fan will continue to operate at its boost speed after the boost has been switched off.)



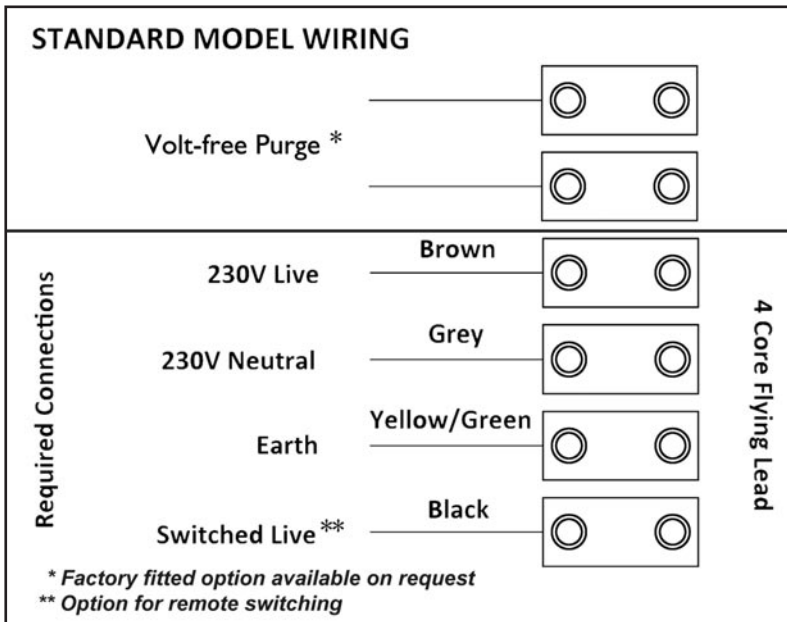

### Commissioning

1. The commissioning must only be carried out by a suitably qualified person.
2. Prior to starting the commissioning procedure, ensure that the ductwork connections and airflow directions match one of the options A or B, shown on page 5. Check that the drain connection is on the correct side.
3. Before making any adjustments, ensure that the air valves or grilles are fully open.
4. **Please see separate "LCD Control Panel Commissioning Instructions" for details on commissioning and user operations.**

**WARNING :** With the control board panel removed, 230 volt live connections are accessible.

### Cleaning and Maintenance

**WARNING:** The unit uses a 230V supply and contains rotating mechanical parts.

Before carrying out any maintenance or cleaning operations the mains electrical supply **MUST** be disconnected.

The heat exchanger within the unit should be cleaned annually.

#### To clean the filters and heat exchanger:

The air filters and heat exchanger of the Vectaire WHHR Maxi/Maxi Plus should be cleaned regularly by a suitably qualified person [the frequency of cleaning will vary depending on the installation environment].

#### Filters:

- Slide out the filters by pulling out the tabs.
- Clean the filters carefully using a vacuum cleaner, replace in the slots and refit the filter covers

#### Heat Exchanger:

- Firstly remove filters as described above
- Remove the screws securing the front panel and carefully lift off. **N.B** When removing the main front cover, it the wires connecting the circuit board to the main front cover must be first disconnected to avoid causing damage to the LCD screen [does not apply to "AT" models]. Using the plastic strap fitted, carefully pull out the heat exchanger.
- Caution: if this is done during cold weather, the heat exchanger may contain water. It is advisable to have a plastic bowl available to avoid spillage.
- Lightly clean the faces of the heat exchanger with a vacuum cleaner. Replace the heat exchanger carefully, by sliding the assembly back into the cabinet.
- Replace the front cover by hooking the top edge into the slots in the cabinet and secure in place using the screws.
- Finally, replace the filters as above.

**Never use water or any other fluids to clean the heat exchanger**

#### Filter Replacement

Filters should be replaced annually or after a maximum of 3 cleaning cycles.

Replacement filters are available from Vectaire - call us on +44(0)1494 522333 or email to sales@vectaire.co.uk